

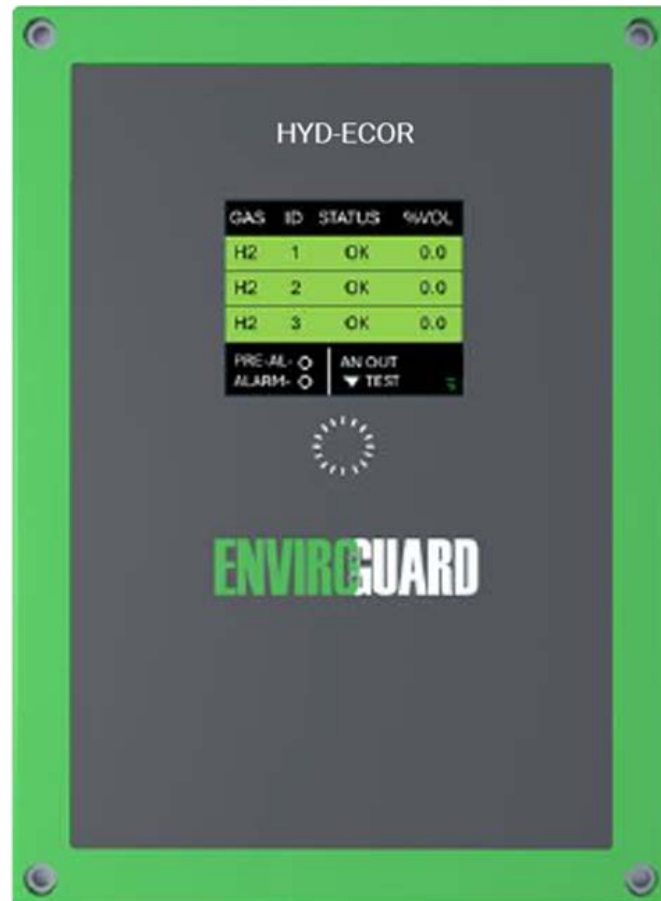

HYD-ECOR

Repeater (Mimic)

Hydrogen (H₂) Detector



Installation, Operation & Maintenance

Please read this manual carefully and retain for future use.

For specific requirements that may deviate from the information in this guide – contact your supplier.

Contents

Important Warning Statements	2
Product Description	3
Overview.....	3
Installation	3
Typical Application & Location	3
Mounting & Cabling	3
Circuit Board Overview.....	4
Power Input.....	5
System Configuration	6
Operation	6
Analogue Outputs	7
Alarm Relays	8
External Strobe Model# HYD-AAB	8
Fire Alarm	9
Factory Default Setting	9
Settings Screen	9
Menu.....	10
Maintenance	11
Cleaning.....	11
Manual Circuit Simulation Test.....	11
Specification	12

Important Warning Statements



Warning Symbol!

Where this symbol is used, the manual must be consulted to understand the nature of any potential hazards and how to avoid them.



Please take the time to thoroughly read these instructions which should be retained for future reference.



It is recommended that this device be commissioned upon installation and serviced annually by a competent person.



Never ignore your device when in alarm.



The device is not intended for use in potentially explosive atmospheres.

Information on waste disposal for consumers of electrical & electronic equipment.

When this product has reached the end of its life it must be treated as Waste Electrical & Electronics Equipment (WEEE). Any WEEE marked products must not be mixed with general household waste, but kept separate for the treatment, recovery and recycling of the materials used. Please contact your supplier or local authority for details of recycling schemes in your area.



At the end of their working life, electrochemical sensors should be disposed of in an environmentally safe manner. Alternatively, they can be securely packaged and returned to S&S Northern clearly marked for disposal. Electrochemical sensors should not be incinerated as this may cause the cell to emit toxic fumes.

Product Description

Overview

The HYD-ECOR is a repeater compatible with HYD-ECO hydrogen gas detectors from software version 1v3 onwards. It can be configured as part of a Hydrogen gas detection system incorporating 3 * HYD-ECO units.

Installation

Typical Application & Location

- ⚠ Installation must be carried out by a licensed, insured contractor!
- ⚠ Ensure that detectors are not exposed to liquid or dust contamination!
- ⚠ Cables must be protected against mechanical damage!
- ⚠ Avoid conditions of any other environmental factors outside of the specification

The HYD-ECOR should be wall-mounted at eye level, allowing good visual access to the display.

Mounting & Cabling

- ⚠ If mounting direct to wall - ensure the wall surface is flat to prevent base distortion!
- ⚠ Ensure the rear base is installed in the correct orientation as shown!
- ⚠ Where cable glands/conduits are used for wire entry, use 20mm (3/4 inch) max separated by at least 20mm!
- ⚠ Any parts that form part of the connections/installation must have a minimum fire-retardant rating of UL94v-2!
- ⚠ Damage to PCBs when creating cable entry points or attempting to remove the circuit board may void any warranty!
- ⚠ The monitor is designed for either surface mounting or mounted on a one or two gang electrical box.
- ⚠ Restrain the hazardous live wiring from accidental loosening to prevent wires from moving after installation and touching parts of opposite polarity or at low voltages!
- ⚠ Isolate the equipment from all hazardous live power sources before opening the cover!

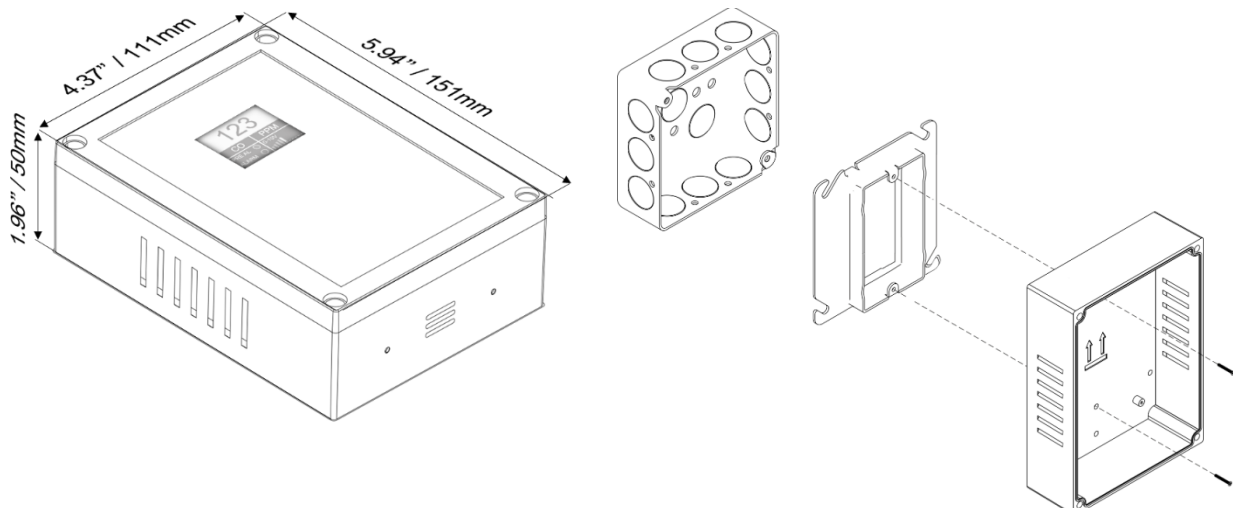

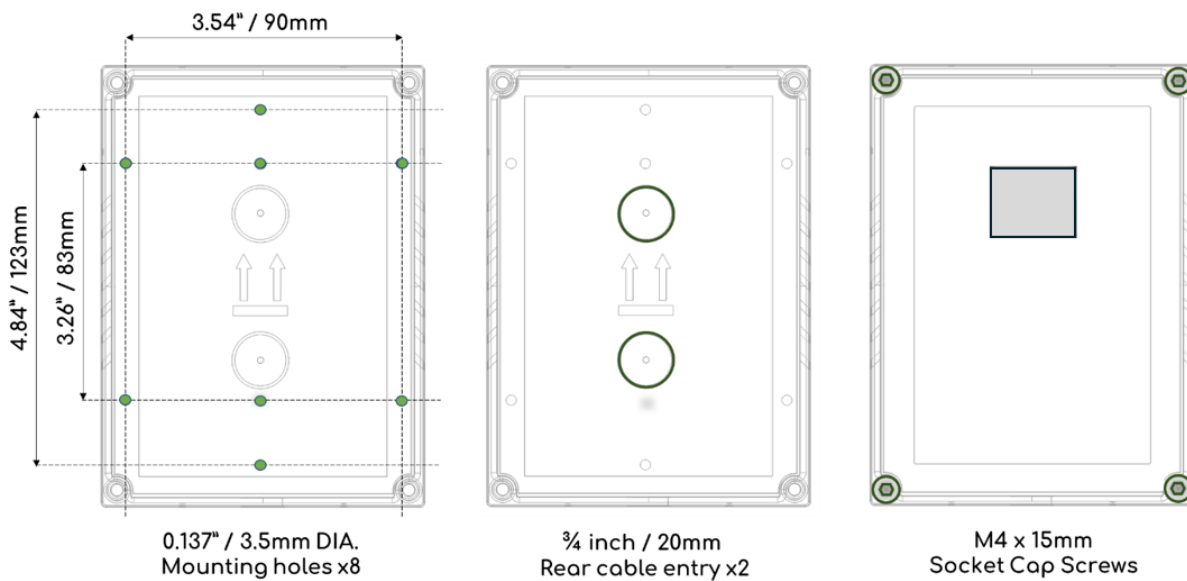

1. Carefully remove the front cover from the unit by using an M3 hex key.
2. Using the rear base - mark mounting holes to the wall or mount to an electrical box.
3. Fixing straight to wall – drill 0.2" (5mm) hole, insert plugs and use the four screws (No.4 Pozi) provided.
4. There are pre-fractured areas for cable entry on the rear of the base and pilot holes positioned on the top and bottom of the enclosure suitable for entry points up to $\frac{3}{4}$ " (20mm). Drill out as necessary ensuring all swarf is removed from the box and holes have smooth edges.
5. After executing the mounting/connections – secure the front cover with all M4 bolts and insert the security caps provided.

Circuit Board Overview

- ⚠ **Damage to PCBs when creating cable entry points may void any warranty!**
- ⚠ **Any damage attempting to remove the circuit board may void any warranty!**
- ⚠ **A disconnecter is required and accessible for the supply and an adequate overcurrent device is fitted!**

Power Input

Power Line In 90~250V AC. Terminals are pluggable types for easier connections.

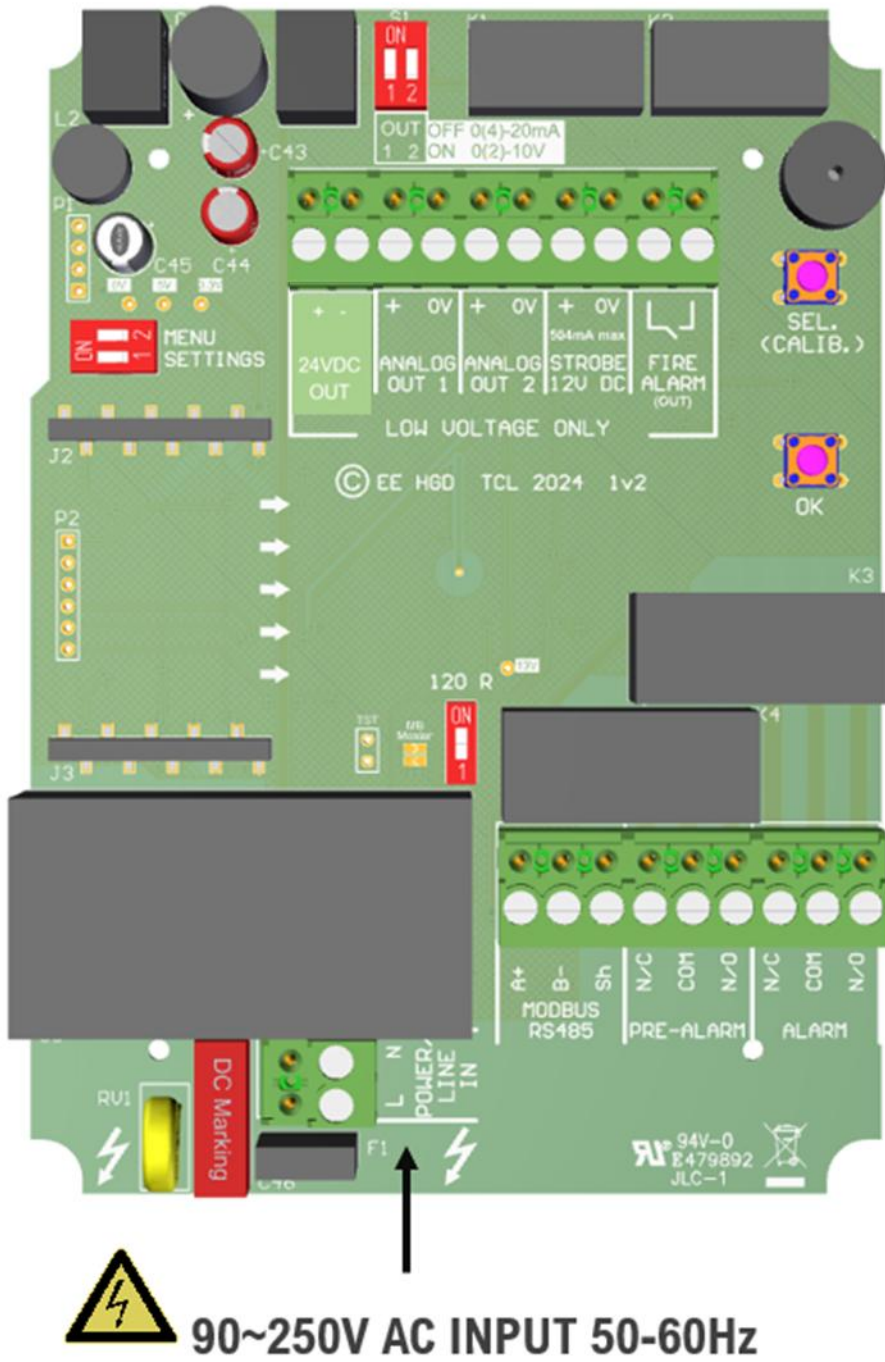

System Configuration

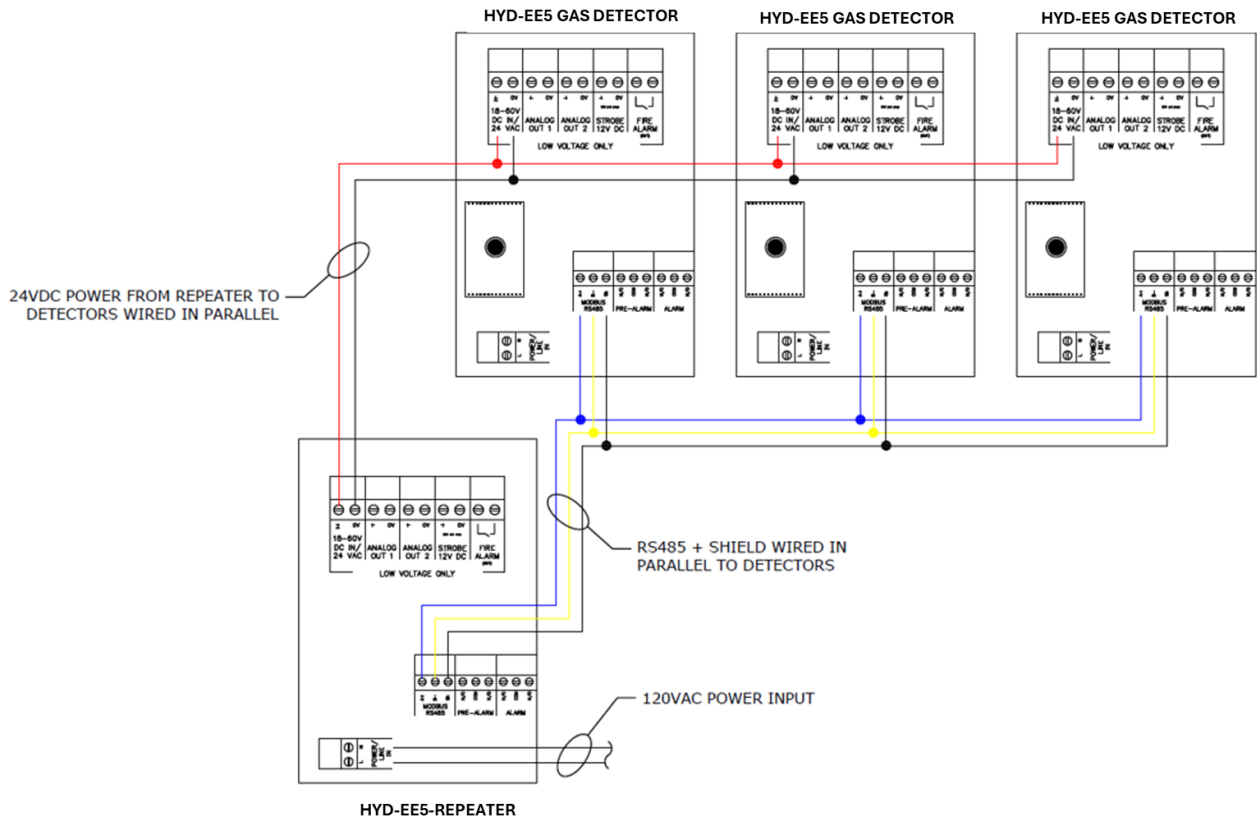

Operation

During initial powering, the detector enters a warmup phase for approximately 60 seconds and scans for connected detectors, during this time the device is not yet ready for operation.



Important: The monitor will require 48hrs of constant powering together with the other HYD-ECO in the system to reach full accuracy.

The repeater can display up to 3 * HYD-ECO hydrogen detectors. Each repeater and detector requires a different Modbus address to avoid communication issues, set the Modbus ID address as required (see section **Settings Screen**)

In normal operation, the repeaters will display the status of the 3 * HYD-ECO units as shown below.

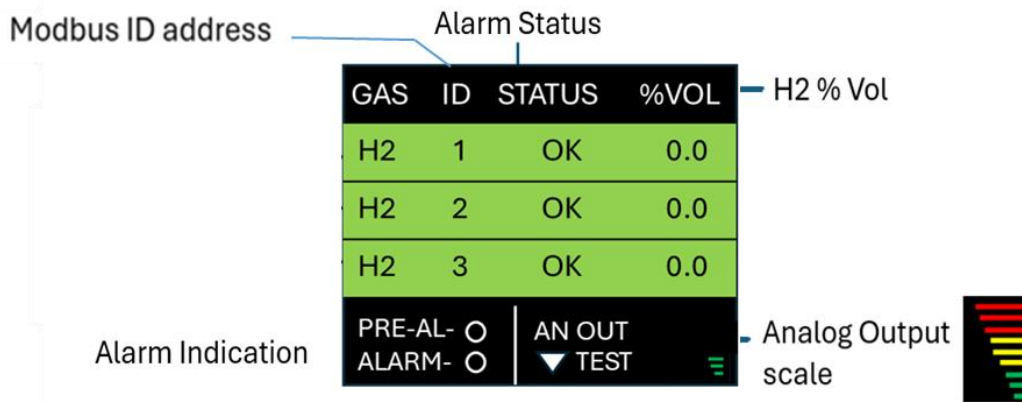

In an alarm state, the internal audible alarm will alert the user that the detector has entered a warning alarm state.

Target Gas	AL1: Pre-Alarm	Buzzer	AL2: Alarm	Buzzer
Hydrogen (H ₂)	1% Vol	None	2% Vol	Continuous sound

Example alarm states for HYD-ECO [ID 1].

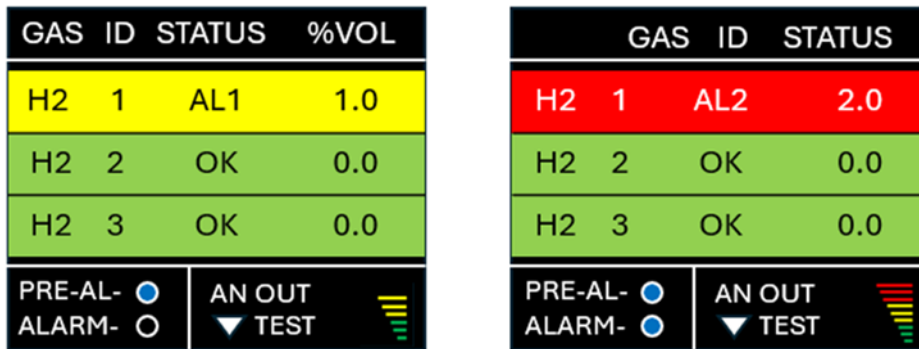

Analogue Outputs

The 0(2)-10V & 0(4)-20mA output is linearly scaled according to the status of gas concentrations detected and follows the highest value from the connected detectors.

Gas	0(4)~20mA	0(2)-10v
H2 Hydrogen: % Vol	0~2%	0~2%

This output can be used to regulate the external fan speed and can be connected directly to fan speed controllers, select 0(2)-10v or 0(4)-20mA from the S1 dip switch.

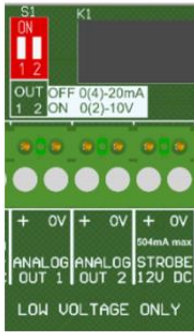

S1 Switch Settings	
S1-1 ON	0(2)-10v Analog Out 1
S1-1 OFF	0(4)-20mA Analog Out 1
S1-2 ON	0(2)-10v Analog Out 2
S1-2 OFF	0(4)-20mA Analog Out 2

Note: Optional 0~4mA and 2-10V outputs can be selected from the settings screen as described in the “Settings Section”.

Alarm Relays

The detector has 10 Amp internal pre-alarm and alarm relays.

PRE-ALARM: When the hydrogen level reaches **1% Vol** the contact will close, this relay is suitable for driving a ventilation system

ALARM: When the hydrogen level reaches **2% Vol** the contact will close, this relay is suitable for activating a danger warning alarm.

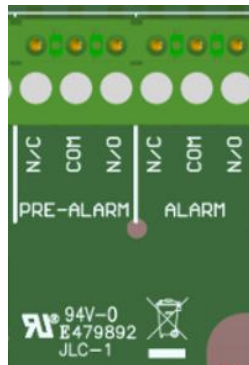

External Strobe Model# HYD-AAB

The Strobe connection provides 12V DC (504mA max) output power to an external strobe and will activate when the Hydrogen level reaches 2% Vol.

The HYD-ECOR is capable of powering up to four (4) HYD-AAB alarm strobes.

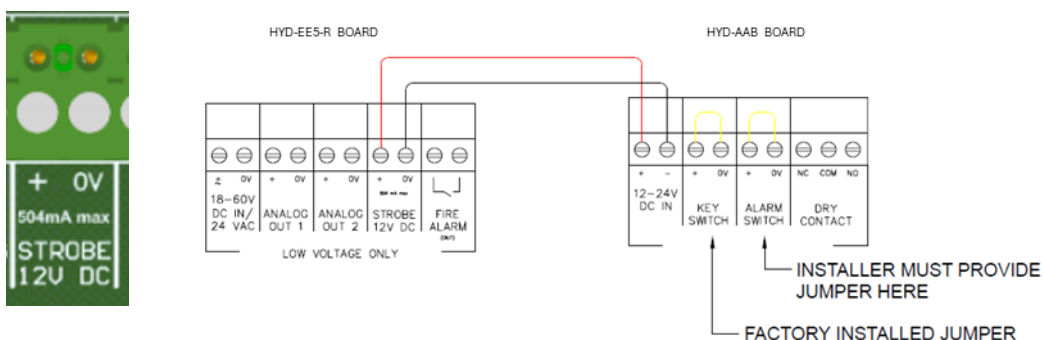

Fire Alarm

The fire alarm connection provides a 1A normally open dry contact output to an external fire alarm, the output will be activated at the warning alarm level of 2% Vol.



Factory Default Setting

Setting	Default
Analog 1	4-20mA
Analog 2	4-20mA
Pre-Alarm Delay(s)	4 Sec
Alarm Delay(s)	4 Sec
Deadband	ON
Relay Latch	OFF

Settings Screen

There is a settings and menu switch on the main board. Switch the **MENU** or **SETTINGS** switch to prompt the on-screen menu.

Navigate the menu using the **SEL** buttons on the main board, press the **OK** button to save desired settings and switch off to return to the normal operating mode.

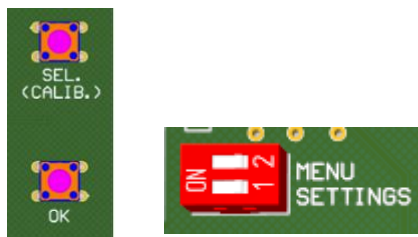

[SEL.] button	[OK] button
Scroll through functions (highlighted in red)	Highlights setting (red)
Change the desired setting when highlighted	Press to save the desired setting.

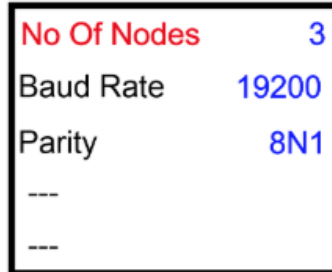

No Of Nodes: Set the number of connected detectors (3 Default)

Modbus Baud Rate: Modbus data exchange speed (bit per second).
 Selection of: 4800, 9600, 19200 (Default), 38400, 57600, 115200.

Parity: 8N1, 8E1 and 8O1 (8N1 Default)

Menu

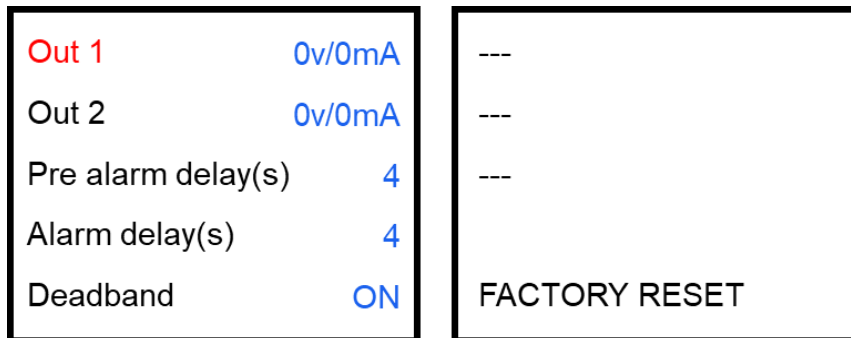

Out 1 - Analogue output 0(2)-10 or 0(4)-20mA
 Selection between 0v / 0mA and 2v / 4mA

Out 2 - Analogue output 0(2)-10 or 0(4)-20mA
 Selection between 0v / 0mA and 2v / 4mA

Pre-Alarm Delay(s) – Delay in seconds for pre-alarm relay activation range from 0-15 second.

Alarm Delay(s) – Delay in seconds for alarm relay activation range from 0-15 second.

Deadband – Set ON/OFF, when ON gas reading < ± 0.3 will be displayed as 0

FACTORY RESET Return to default condition. YES / NO

Maintenance

Cleaning

Keep your repeater in good working order.

- Remove any dust/debris from the outer enclosure regularly using a slightly damp cloth.

Manual Circuit Simulation Test

 **This circuit test does not check the gas-sensing element itself!**

Press the self-test button for 3 seconds to select the self-test mode. Press the button again to select THE unit ID to test (All, 1, 2, or 3) The selected unit will be displayed in green, wait until the test automatically activates. The detector will simulate a self-test of the selected units checking the outputs, alarms, indications, and other external devices are operating as intended. The test sequence will automatically terminate after a short period of time and return to normal operation.



Specification

General	
Model:	HYD-EECOR
System Target Gases:	Repeater for Hydrogen Gas Detection System
Size: (H x W x D)	5.95 x 4.37 x 1.97" (151 x 111 x 50mm)
Housing Material:	ABS PA765. Flame Retardant UL 94V-1
Mounting:	Safe Zone - Indoor use - Wall Mounted
Weight:	212g
User Interface	
Display:	1.8" TFT
Screen Brightness:	Non-Adjustable
Visual Indicators:	Gas Level (Green: Normal; Yellow: Pre-Alarm; Red: Alarm)
Audible Alarm:	>80dB @ 3.28ft (1m). Quiet conditions.
Language:	English
Power Supply	
Rated Power:	26 VA @ 120VAC
Rated Voltage:	90-250 VAC
Relays	
Fire alarm relay	1A
Pre-alarm 1% Vol (25% LEL) Main alarm 2% Vol (50% LEL) voltage-free relay outputs:	10A switching current (resistive load)
Environmental	
Operating:	14~104°F / 20 ~ 90% RH (non-condensing)
Storage:	14~104°F / 20 ~ 90% RH (no condensation)
Altitude Rating:	2000m
Wiring	
Typical	Power wiring should apply to all applicable codes. 120VAC & alarm relay outputs 14-16AWG / 24V DC 16-18AWG
Approvals	
Electrical Safety & EMC	CE / UKCA BS EN 61010-1:2010 +A1:2019. & BS EN 50270 / FCC CRF 47part 15B



EnviroGuard - www.enviroguard.com

800-975-4421